

KV 1/2" solenoid valves are designed for small hydraulic lifts operating at speeds up to 0.16 m/s (32 fpm) depending on the valve selected. The smooth and accurate ride characteristics of the KV2S valve which includes 'soft stop' in both directions, render it highly suitable for quality home lifts and lifts for the handicapped.

**Flow Range:** 5-80 l/min (1.3-21 US gpm) - see flow pressure charts

**Pressure Range:** 8-100 bar (116-1450 psi)

**Burst Pressure:** 500 bar (7251 psi)

**Solenoids AC:** 24 V/1.8 A, 42 V/1.0 A, 110 V/0.5 A, 230 V/0.18 A, 50/60 Hz

**Insulation Class, AC and DC:** IP 68

**Solenoids DC:** 12 V/2.1 A, 24 V/1.1 A, 42 V/0.6 A, 80 V/0.3 A, 125 V/0.25 A, 196 V/0.14 A.

**Oil Viscosity:** 25-60 cSt. at 40°C (104°F)

**Max. Oil Temperature:** 70°C (158°F)

**Operation oil temperature range:** 10°C-60°C (50°F-140°F), for oil VGA46: 250cSt.-20 cSt.

**Optimal oil temperature range:** 25°C-55°C (77°F-131°F), for oil VGA46: 100cSt.-24 cSt.

**Ambient temperature range:** 0°C-70°C (32°F-158°F)



#### Speeds max. (EN code)

### KV1P

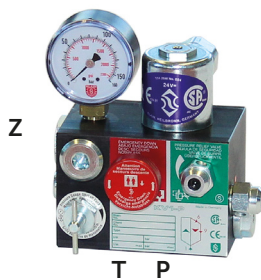

1.8 kg

- Up** One up speed, 0.16 m/s (32 fpm) max.  
Up start has built-in damping.  
Up stop has no damping (pump stops).
- Down** One down speed, 0.16 m/s (32 fpm) max.  
Down start has adjustable damping.  
Down speed is adjustable.  
Down stop has built-in damping.

### KV1S



2.3 kg

- Up** One up speed 0.16 m/s (32 fpm) max. with soft stop, or 0.4 m/s (80 fpm) max. with overtravel and relevelling.  
Up start has built-in damping.  
Up stop has adjustable damping (delayed pump stop required).
- Down** One down speed, 0.16 (32 fpm) max.  
Down start has adjustable damping.  
Down speed is adjustable.  
Down stop has built-in damping.

### KV2P



2.5 kg

- Up** One up speed, 0.16 m/s (32 fpm) max.  
Up start has built-in damping.  
Up stop has no damping (pump stops).
- Down** Two down speeds, 1 m/s (200 fpm) max.  
Down start has adjustable damping.  
Fast down speed and levelling speeds are adjustable.  
Slow down and stop have built-in damping.

### KV2S



3.2 kg

- Up** One up speed, 0.16 m/s (32 fpm) max. with soft stop, or 0.4 m/s (80 fpm) max. with overtravel and relevelling.  
Up start has built-in damping.  
Up stop has adjustable damping (delayed pump stop required).
- Down** Two down speeds, 1 m/s (200 fpm) max.  
Down start has adjustable damping.  
Fast down speed and levelling speeds are adjustable.  
Slow down and stop have built-in damping.

Blain Hydraulics GmbH Tel. +49 7131 28210  
Pfaffenstrasse 1 Fax +49 7131 282199  
74078 Heilbronn www.blain.de  
Germany info@blain.de



GmbH

Designer and Manufacturer of the highest quality control valves & safety components for hydraulic elevators



SP®  
B44.1  
C US  
ASME-A17.1



### Control Elements

- A Solenoid 'Up Stop'
- C Solenoid 'Down Deceleration'
- D Solenoid 'Down Stop'
- U Bypass Valve
- H Manual Lowering

- V Check Valve
- X Down Valve
- Y Down Level Valve
- F Main Filter
- S Relief Valve

### Adjustments UP

- 1 Bypass
- 5 Up Soft Stop
- Up Acceleration built-in*

### Adjustments DOWN

- 6 Down Acceleration
- 7 Down Full Speed
- 9 Down Levelling Speed
- Down Deceleration built-in*

### Hydraulic Circuit

### Electrical Sequence

#### KV1P

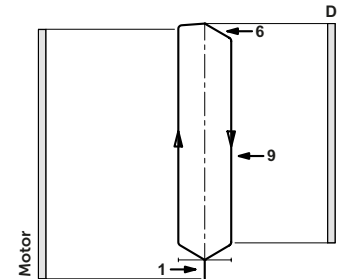
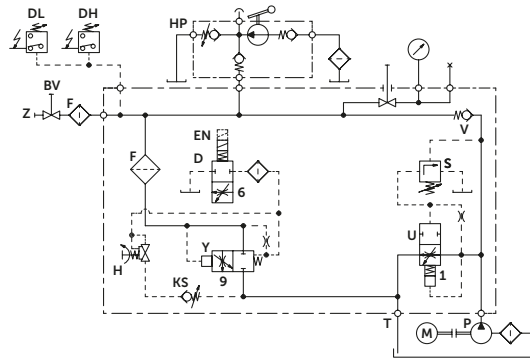
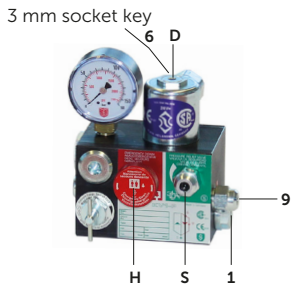

#### KV1S

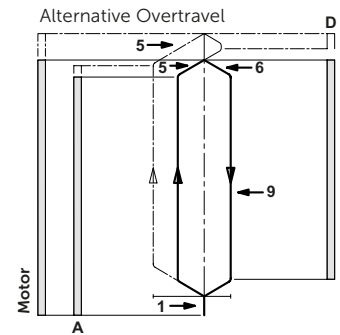
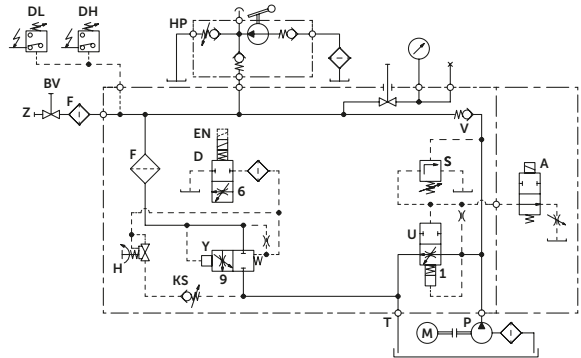
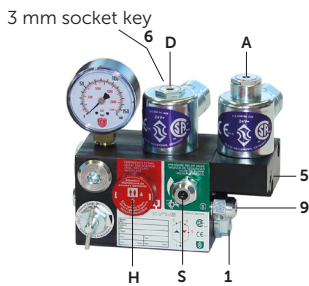

#### KV2P

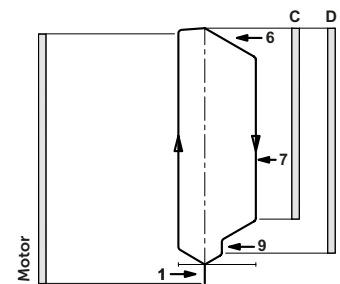
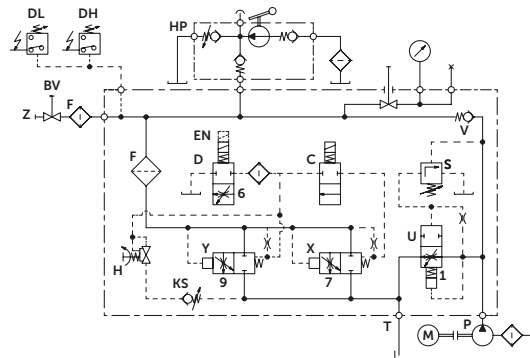
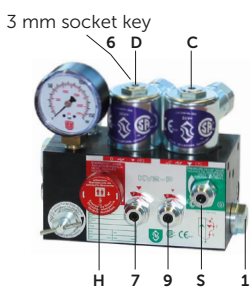

#### KV2S

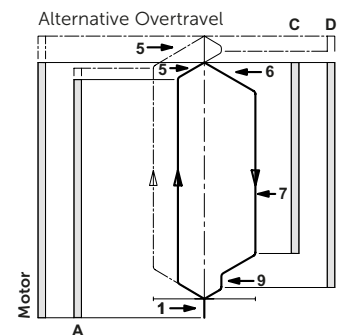
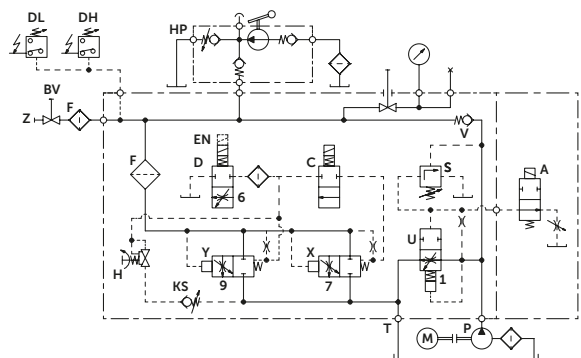
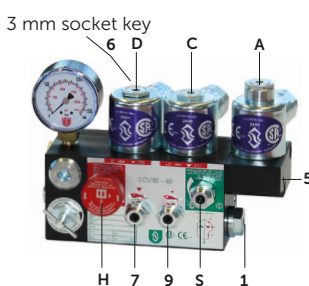



**Warning:** Only qualified personnel should adjust or service valves. Unauthorised manipulation may result in injury, loss of life or damage to equipment. Prior to servicing internal parts, ensure that the electrical power is switched off, cylinder line is closed and residual pressure in the valve is reduced to zero.



## Adjustments UP

**Valves are already adjusted and tested.** Check electrical operation before changing valve settings. Test that the correct solenoid is energized, by removing the nut and raising the solenoid slightly to feel pull.

**Nominal Settings:** Adjustment **1** level with flange faces. Adjustment **5** (KV1S & KV2S) level with flange faces.

- KV1P**
- 1. Up Bypass:** When the pump is started, the unloaded car should remain stationary at the floor for a period of about 1 second before starting upwards. The length of this delay is according to the setting of adjustment **1**. 'In' (clockwise) shortens the delay, 'out' (c-clockwise) lengthens the delay.  
**Up Stop:** At floor level, the pump-motor is de-energized. The stop may be abrupt depending on load and speed of approach. No adjustment possible.
  - S Relief Valve:** 'In' (clockwise) produces a higher, 'out' (c-clockwise) a lower maximum pressure setting. After turning 'out', open manual lowering **H** for an instant.  
**Important: When testing relief valve, close ball valve gradually.**

- KV1S**
- 1. Up Bypass:** When the pump is started, the unloaded car should remain stationary at the floor for a period of about 1 second before starting upwards. The length of this delay is according to the setting of adjustment **1**. 'In' (clockwise) shortens the delay, 'out' (c-clockwise) lengthens the delay.
  - 5. Up Stop:** At floor level solenoid **A** is de-energized. Through a time relay the pump must run approx. 1 seconds longer to allow the car to stop smoothly by valve operation according to the setting of adjustment **5**. 'In' (clockwise) provides a softer stop, 'out' (c-clockwise) a quicker stop. Pre-adjustment: With solenoid **A** disconnected and the pump running, **5** should be turned in until the car starts to move up, then slowly backed off again until the car stops.  
**Alternative Up Stop:** At relatively higher speeds and with the time relay arrangements as with 'up stop' above, the car may travel to just above floor level. In overtravelling the floor, down levelling solenoid **D** is energized, lowering the car smoothly back down to floor level where **D** is de-energized.
  - S Relief Valve:** 'In' (clockwise) produces a higher, 'out' (c-clockwise) a lower maximum pressure setting. After turning 'out', open manual lowering **H** for an instant.  
**Important: When testing relief valve, close ball valve gradually.**

- KV2P**
- 1. Up Bypass:** When the pump is started, the unloaded car should remain stationary at the floor for a period of about 1 second before starting upwards. The length of this delay is according to the setting of adjustment **1**. 'In' (clockwise) shortens the delay, 'out' (c-clockwise) lengthens the delay.  
**Up Stop:** At floor level, the pump-motor is de-energized. The stop may be abrupt depending on load and speed of approach. No adjustment possible.
  - S Relief Valve:** 'In' (clockwise) produces a higher, 'out' (c-clockwise) a lower maximum pressure setting. After turning 'out', open manual lowering **H** for an instant.  
**Important: When testing relief valve, close ball valve gradually.**

- KV2S**
- 1. Up Bypass:** When the pump is started, the unloaded car should remain stationary at the floor for a period of about 1 second before starting upwards. The length of this delay is according to the setting of adjustment **1**. 'In' (clockwise) shortens the delay, 'out' (c-clockwise) lengthens the delay.
  - 5. Up Stop:** At floor level solenoid **A** is de-energized. Through a time relay the pump must run approx. 1 seconds longer to allow the car to stop smoothly by valve operation according to the setting of adjustment **5**. 'In' (clockwise) provides a softer stop, 'out' (c-clockwise) a quicker stop. Pre-adjustment: With solenoid **A** disconnected and the pump running, **5** should be turned in until the car starts to move up, then slowly backed off again until the car stops.  
**Alternative Up Stop:** At relatively higher speeds and with the time relay arrangements as with 'up stop' above, the car may travel to just above floor level. In overtravelling the floor, down levelling solenoid **D** is energized, lowering the car smoothly back down to floor level where **D** is de-energized.
  - S Relief Valve:** 'In' (clockwise) produces a higher, 'out' (c-clockwise) a lower maximum pressure setting. After turning 'out', open manual lowering **H** for an instant.  
**Important: When testing relief valve, close ball valve gradually.**



**Warning:** Only qualified personnel should adjust or service valves. Unauthorised manipulation may result in injury, loss of life or damage to equipment. Prior to servicing internal parts, ensure that the electrical power is switched off, cylinder line is closed and residual pressure in the valve is reduced to zero.



## Adjustments DOWN

**Valves are already tested and adjusted.** Check electrical operation before changing valves settings. Test that the correct solenoid is energized by removing nut and raising solenoid slightly to feel pull.

**KV Nominal Settings:** Adjustments **7 & 9**, screwheads level with the hexagon heads.

### KV1P / KV1S

**6. Down Acceleration:** When solenoid **D** is energized, the car will accelerate downwards according to the setting of adjustment **6**. 'In' (clockwise) provides a softer down acceleration, 'out' (c-clockwise) a quicker acceleration. Pre-adjustment: **6** should be turned all the way in and then solenoid **D** energized. Turn **6** slowly back out until the car accelerates downwards.

**9. Down Speed:** With solenoid **D** energized as above, the down speed of the car is according to the setting of adjustment **9**. 'In' (clockwise) provides a slower down speed, 'out' (c-clockwise) a faster down speed.

**Down Stop:** At floor level, solenoid **D** is de-energized causing the car to stop. No adjustment necessary.

**H Manual Lowering:** 'out' (c-clockwise) allows the car to be lowered by hand. Closes automatically on release.

### KV2P / KV2S

**6. Down Acceleration:** When solenoids **C** and **D** are energized, the car will accelerate downwards according to the setting of adjustment **6**. 'In' (clockwise) provides a softer down acceleration, 'out' (c-clockwise) a quicker acceleration. Pre-adjustment: **6** should be turned all the way in and then solenoid **C** and **D** energized. Turn **6** slowly back out until the car accelerates downwards.

**7. Down Speed:** With solenoids **C** and **D** energized as above, the down speed of the car is according to the setting of adjustment **7**. 'In' (clockwise) provides a slower down speed, 'out' (c-clockwise) a faster down speed.

**Down deceleration:** When solenoid **C** is de-energized whilst solenoid **D** remains energized, the car will decelerate according to the built-in damping. No further adjustment will be required.

**9. Down Levelling:** With solenoid **C** de-energized and solenoid **D** remaining energized, the car will travel at its down levelling speed according to the setting of adjustment **9**. 'In' (clockwise) provides a slower, 'out' (c-clockwise) a faster down levelling speed.

**Down Stop:** At floor level, solenoid **D** is de-energized causing the car to stop. No adjustment necessary.

**H Manual Lowering:** 'out' (c-clockwise) allows the car to be lowered by hand. Closes automatically on release.

**KS Slack Rope Valve:** Solenoid **D** must be de-energised! The KS, is adjusted with a 3 mm Allan Key by turning the screw **K** 'in' for higher pressure and 'out' for lower pressure. With **K** turned all the way 'in', then half a turn back out, the unloaded car should descend when Manual Lowering **H** is opened. Should the car not descend, **K** must be backed off until the car just begins to descend, then backed off a further half turn to ensure that with cold oil, the car can be lowered as required.

## Optional

### KV Optional Equipment

- BV** Ball Valve built in
- EN** Emergency Power Solenoid
- HP** Hand Pump H 13
- KS** Slack Rope Valve
- DH** Pressure Switch 10-100 bar
- DL** Pressure Switch 1-10 bar
- CSA** CSA Solenoids
- HA** Emergency Manual Down Speed Adj.

The possible options are shown with KV1P Valve.  
The same Options can be applied to all other KV Valve types.

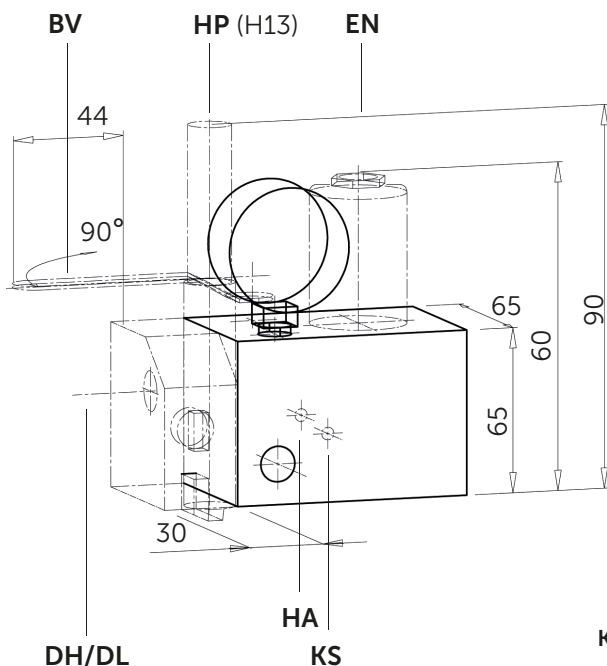

KV Example with Options



## KV1P & KV1S

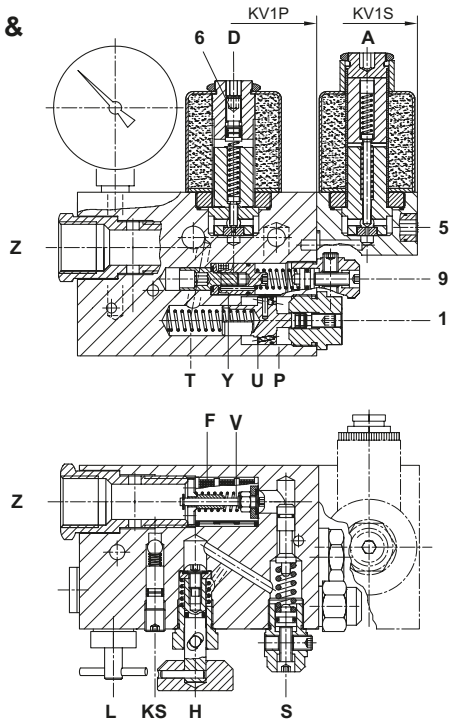

## KV2P & KV2S

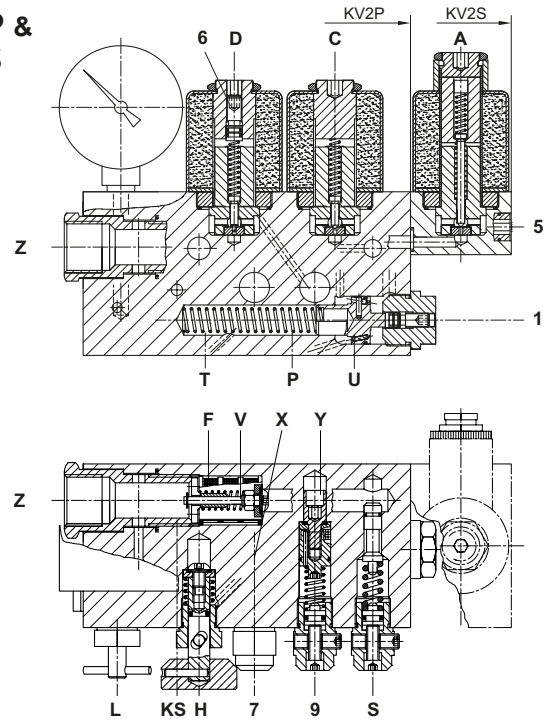

### Control Elements

- A Solenoid ,Up Stop'
- C Solenoid ,Down Deceleration'
- D Solenoid ,Down Stop'
- U Bypass Valve
- V Check Valve
- X Down Valve
- Y Down Levelling Valve
- H Manual Lowering
- L Gauge Shut Off Cock
- F Main Filter

### Connections

- P Pump
- T Tank - return
- Z Cylinder

### Adjustments

- 1 Bypass
- 5 Soft Stop ,Up'
- 6 Start ,Down'
- 7 Speed ,Down'
- 9 Levelling ,Down'
- S Relief Valve



Important: Length of 1/2" thread on pipe connections should not be longer than 14 mm!

## Measurements

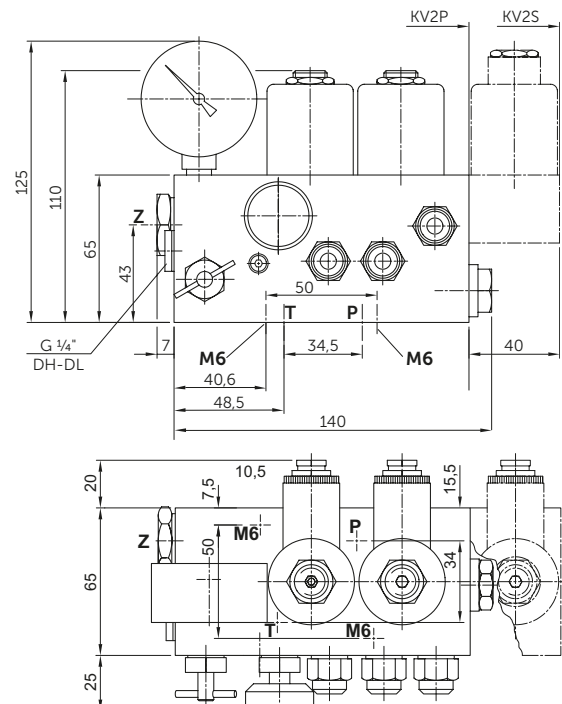
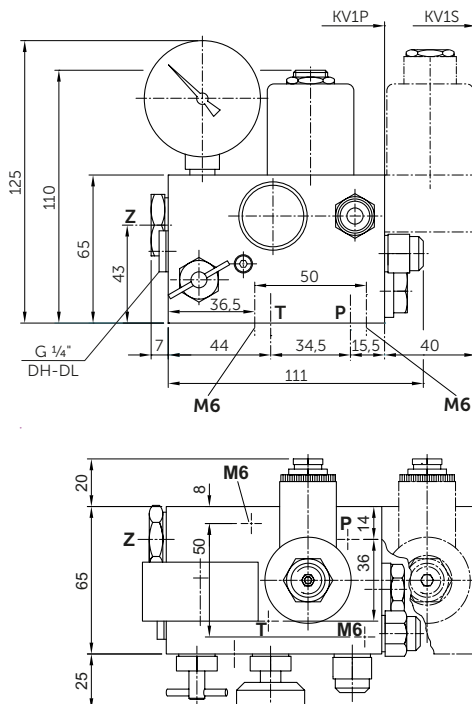





Pos.	No.	Item
1	1F	Flange - Bypass
	1E	Adjustment - Bypass
	EO	O-Ring - Adjustment (3,5x1,5 - P)
	U	Flow Guide - Bypass
	UO	O-Ring - Bypass (17x1 - V)
	UF	Spring - Bypass
5	5	Adjustment - Up Stop
6	6	Adjustment - Down Acceleration
7+9	7E	Adjustment - Down Valve
	9F	Spring - Down Valve
	YO	O-Ring - Flow Guide (10x1 - V)
	XO	Seal - Flow Guide (5.28x1.78 - V)
	XT	O-Ring Disc
	FI	Filter - Down Valve
	X	Down Flow Guide (Brass)
	Y	Down Levelling Flow Guide (Steel) - KV2
	Y	Down Flow Guide (Steel) - KV1
	S	SE
SM		Hexagonal - Relief Valve
MS		Locking Screw
SO		O-Ring - Nipple
SZ		Nipple - Relief Valve
SK		Piston - Relief Valve
H	H	Manual Lowering - Self Closing
	HO	Seal - Man. Lowering (O-Ring 5.28x1.78 - V)
HA	HA	Adjustable Manual Lowering
KS	KS	Slack Rope Valve
A	MM	Nut Solenoid
	AD	Collar Solenoid
	M	Coil Solenoid (indicate voltage)
	AR	Tube Solenoid 'Up'
	MO	O-Ring Solenoid
	AN	Needle Solenoid 'Up'
	AF	Spring Solenoid 'Up'
	AH	Seat Housing 'Up'
	AS	Seat Solenoid 'Up'
	C+D	M
DR		Tube - Solenoid 'Down', w/o adj. 6
DR6		Tube Solenoid 'Down', with adj. 6
MO		O-Ring Solenoid
DF		Spring Solenoid 'Down'
C		DN Needle Solenoid 'Down'
D		N6 Needle Solenoid 'Down' (Nipple)
C		HN Needle Solenoid 'Down'
C		DK Core Solenoid 'Down'
C		DG Seat Housing 'Down'(Solen.D with screen)
C	S6 Seat Solenoid 'Down'	
C	CO O-Ring Seat Housing	
Z	ZA	Cylinder Thread Connection
	V	Check Valve
	VO	O-Ring Check Valve (5,28x1,78 - V)
	F	Main Filter
L	L	Gauge Shut Off Cock

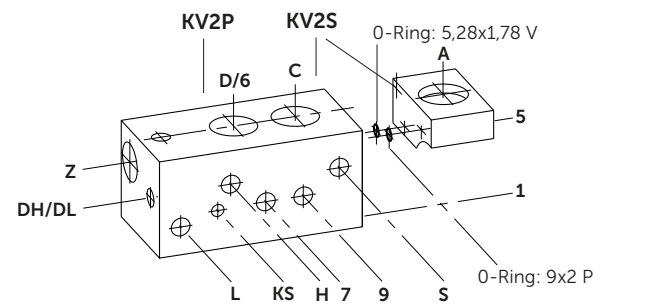
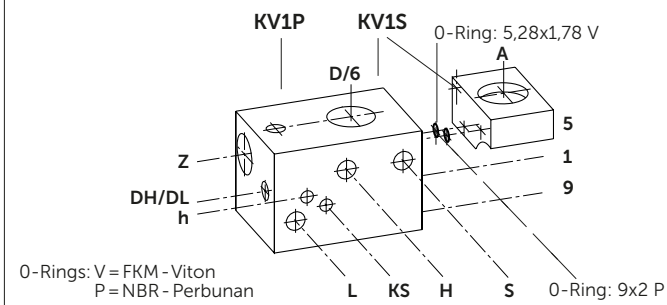
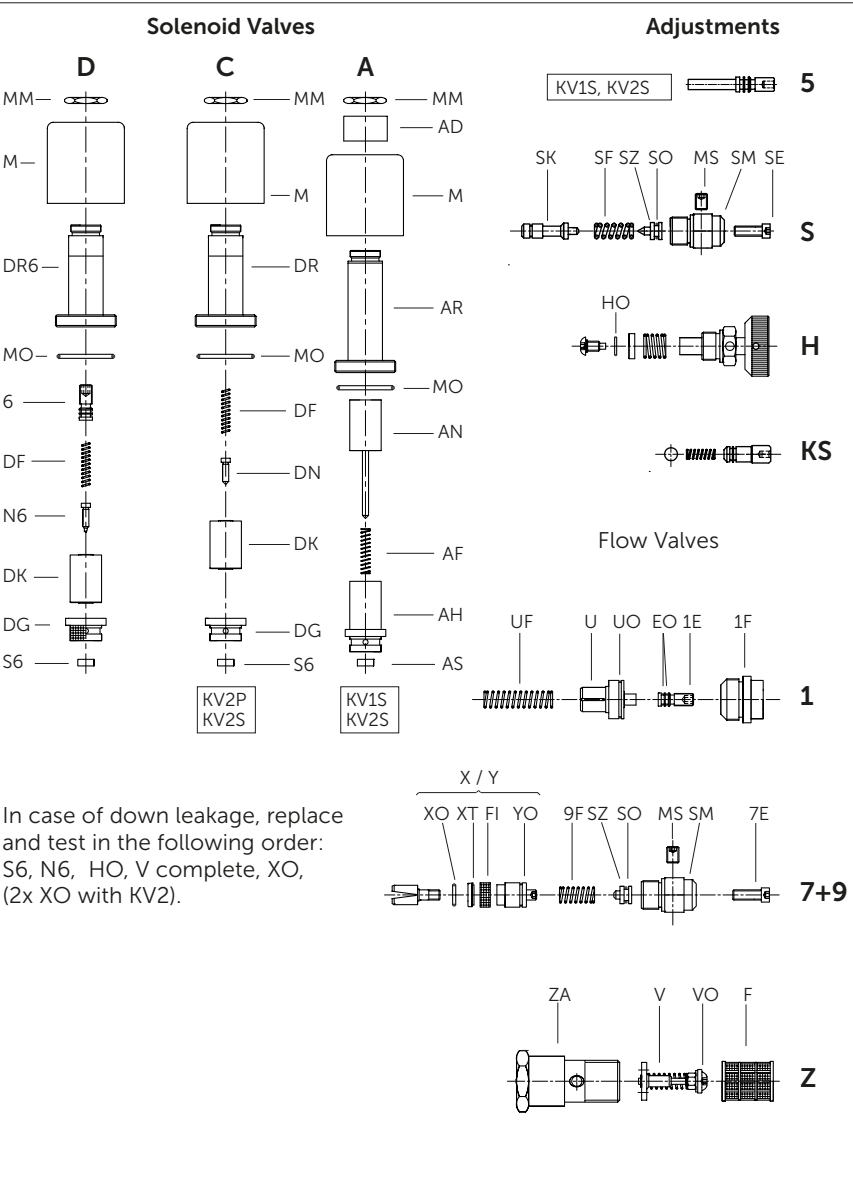

### Insert Selection and Down Flow Chart

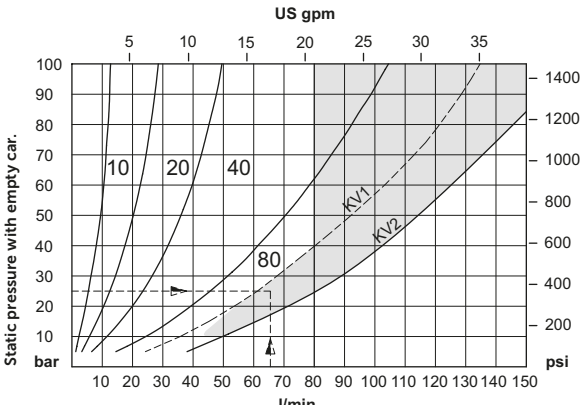

For pressure-flow condition within shaded area, use 3/4" piping to avoid unnecessary pressure loss. Pump flows above 80 l/min are not recommended.

**Example order**  
KV2S, 65 l/min, 25 bar (empty), 220 AC  
or: KV2S/80/220 AC

### Pressure Drop P - Z

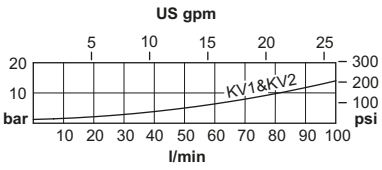

### Lowest Relief Pressure

